

x polarization of this band and x polarization of the phosphorescence with respect to this band. In contrast to the case of coumarylpyrone, direct spin-orbit coupling is between $^3(\pi, \pi^*)$ and $^1(n, \pi^*)$ states and thus out-of-plane phosphorescence is dominant for coumarin.⁸

Finally, Figure 9 illustrates three possible Jablonski diagrams which accommodate the luminescence and lifetime data listed in Table III. Coumarylpyrone may be described by diagram b. These diagrams are presented only as a qualitative guide for interpreting the spectroscopic behavior of coumarins and psoralens, and more definite diagrams will not be possible until the locations of $^1, ^3(n, \pi)$ as well as upper $^3(\pi, \pi^*)$ states are experimentally determined.

Conclusions

(1) Relatively high-resolution studies and vibrational analysis of the phosphorescence of a series of coumarins and psoralens provide evidence that the $^3(\pi, \pi^*)$ states of most of these compounds are partially localized in the C=C bond of the pyrone moiety.

(2) The polarized phosphorescence spectra of psoralens were found to be similar to those of coumarins. However, polarization values (in degrees) of the former are generally more positive (*i.e.*, more in-plane component) with respect to $\pi \rightarrow \pi^*$ excitations than the latter. This probably reflects the contribution of unequal permanent dipole moments of S_0 and T_1 states of psoralens to the $T_1 \rightarrow S_0$ transition dipole *via* S_0-T_1 spin-orbit coupling. The spin-orbit coupling between the 3A_1 and 1B_1 states of coumarylpyrone (C_{2v}) can account for the dominant in-plane intensity of the 0-0 phosphorescence.

(3) Photobiological reactivities of coumarins and

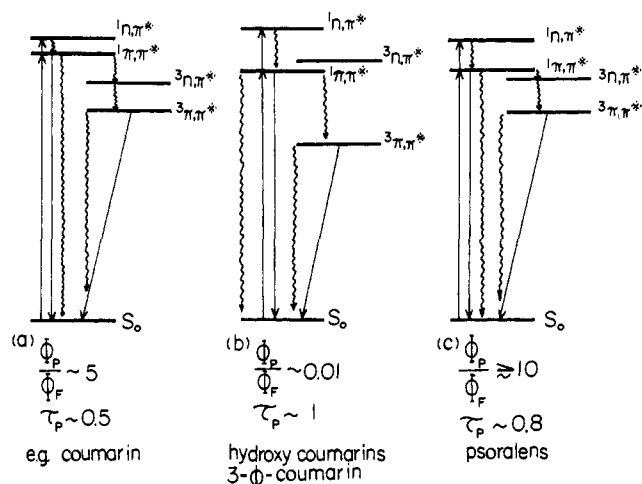

Figure 9. Approximate Jablonski diagrams. Wavy lines represent radiationless transitions which are assumed to be inversely proportional to the energy separation between the initial and final states.

psoralens as skin sensitizers can be described in terms of the localized $^3(\pi, \pi^*)$ state, which is known to be the reactive state, for cycloaddition to the DNA pyrimidine bases. In this connection, coumarylpyrone possessing two reactive C=C bonds can be used as a crosslinking agent of a double helix DNA.

Acknowledgments. Preliminary experiments were carried out by M. L. Harter. The Paul B. Elder Company has generously supplied us with 8-methoxy-psoralen and 4,5',8-trimethylpsoralen in the later stage of this work, when these compounds were needed. Thanks are also due the Texas Tech University Institute of Environmental Chemistry for a grant.

Ring Inversion in Dioxene. Comparison of the Barrier Heights by Nuclear Magnetic Resonance and Far-Infrared Measurements

R. H. Larkin and R. C. Lord*

Contribution from the Spectroscopy Laboratory and the Department of Chemistry, Massachusetts Institute of Technology, Cambridge, Massachusetts 02139. Received February 26, 1973

Abstract: The temperature dependence of the proton nmr spectrum of 1,4-dioxene has been measured from -150° to room temperature. Line-shape analysis yields a barrier to inversion of the twisted ring of 7.62 ± 0.15 kcal/mol. This number agrees within experimental error with the energy of the saddle point on the potential surface that represents the minimum required for inversion as determined by high-resolution far-infrared spectroscopy. From the angular dependence of the vicinal proton coupling constants, a twist angle of 39.3° was calculated. This compares with 48.54° estimated from the potential surface as mapped from the far-infrared data.

In recent years the barriers to inversion for a number of four-membered and five-membered ring compounds have been determined by high-resolution far-infrared spectroscopy.¹⁻⁴ In four-membered rings the

(1) C. S. Blackwell and R. C. Lord, "Vibrational Spectra and Structure," J. R. Durig, Ed., Marcel Dekker, New York, N. Y., 1972, Chapter 1.

problem can be treated with good accuracy as one dimensional because the vibrational modes of high fre-

(2) J. Laane, "Vibrational Spectra and Structure," J. R. Durig, Ed., Marcel Dekker, New York, N. Y., 1972, Chapter 2.

(3) C. S. Blackwell, L. A. Carreira, J. R. Durig, J. M. Karriker, and R. C. Lord, *J. Chem. Phys.*, **56**, 1706 (1972).

(4) T. Ikeda and R. C. Lord, *J. Chem. Phys.*, **56**, 4450 (1972).

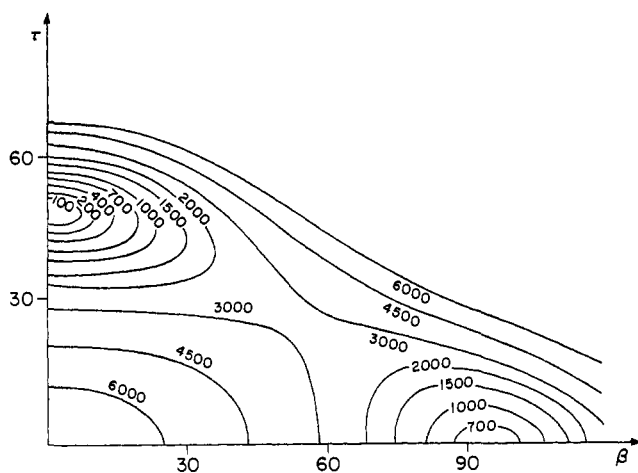

Figure 1. The potential surface for 1,4-dioxene calculated from far-infrared data.¹⁰ Coordinates are bending angle β and twisting angle τ in degrees; energy contours are in cm^{-1} .

quency can be separated from the low-frequency ring-inversion vibration. In saturated five-membered rings this is no longer possible because the bending and twisting frequencies, which are degenerate in cyclopentane, are of comparable value. More elaborate potential functions in the bending and twisting coordinates are needed, and a potential surface is generated when the two-dimensional problem is solved. A recent example of this kind of treatment is that of Ikeda and Lord⁴ for cyclopentanone.

In six-membered rings the problem is further complicated by an additional low-frequency out-of-plane vibration. Until recently the only six-membered ring treated quantitatively by far-infrared methods was 1,4-cyclohexadiene.⁵ This case is exceptional, however, because the rigidity of the two halves of the six-membered ring separates the ring bending at about 108 cm^{-1} from the other two vibrations at substantially higher frequencies.

Much work on inversion in six-membered rings has also been carried out by means of dynamic nmr measurements.⁶⁻⁹ Up to the present time, unfortunately, molecules having anharmonic potential surfaces with sufficiently low barriers to be accessible to study by the far-infrared method have inversion barriers below the range that can be determined from the temperature dependence of nmr spectra.

Recently Lord, *et al.*,¹⁰ investigated the far-infrared spectrum of 1,4-dioxene vapor at high resolution. They assigned the rather complex spectrum to a variety of transitions involving the twisting and bending modes of this molecule and were able to compute a potential surface in these two coordinates. From the potential surface they concluded that the most stable conformation is a twisted (half-chair) form (I) which is in equilibrium with its mirror image (II).

(5) J. Laane and R. C. Lord, *J. Mol. Spectrosc.*, **39**, 340 (1971).

(6) G. Binsch, "Topics in Stereochemistry," Vol. 3, E. L. Eliel and N. L. Allinger, Ed., Interscience, New York, N. Y., 1968.

(7) F. A. L. Anet and M. Z. Haq, *J. Amer. Chem. Soc.*, **87**, 3147 (1965).

(8) F. R. Jensen and C. H. Bushweller, *J. Amer. Chem. Soc.*, **87**, 3285 (1965).

(9) J. E. Anderson and J. D. Roberts, *J. Amer. Chem. Soc.*, **92**, 97 (1970).

(10) R. C. Lord, T. C. Rounds, and T. Ueda, *J. Chem. Phys.*, **57**, 2572 (1972).

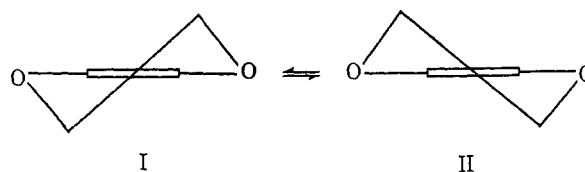

The potential surface, reproduced in Figure 1, implies a barrier to ring inversion of 2886 cm^{-1} (8.26 kcal/mol), which is within the range of study of nmr methods. The room-temperature nmr spectrum of dioxene is consistent with a rapid inversion process since only a single line is observed for the pseudoaxial and pseudo-equatorial methylene protons. Upon investigation of the nmr spectrum of 1,4-dioxene in vinyl chloride solution at -150° , we have found that the inversion process is sufficiently retarded to enable a complex spin-spin coupling pattern as well as the different chemical shifts for axial and equatorial methylene protons to be resolved. It has been possible by line-shape analysis to compute the inversion barrier from the temperature dependence of the nmr spectrum.

The value obtained agrees within experimental error with the energy of the saddle point in Figure 1 that represents the least energy needed to pass from the right-hand potential minimum to the left-hand minimum. Correction must, of course, be made for the zero-point energy, which is readily calculated from the data of ref 10 to be 0.68 kcal/mol.

Experimental Section

Dioxene was prepared by the method of Moss and Paige¹¹ with no essential modification. The product was vacuum distilled and was found by nmr, ir, and gas chromatography methods to be at least 99% pure. Approximately 10% solutions of dioxene in vinyl chloride were made by vacuum distillation of dioxene, vinyl chloride, and a small amount of tetramethylsilane into an nmr tube. The tube was then sealed under vacuum. Spectra were obtained on a Perkin-Elmer Model R20B (60 MHz) spectrometer, equipped with a Perkin-Elmer Model R202 VT variable temperature unit, and on a Varian HA-100 (100 MHz) spectrometer, equipped with a Varian Model V-6040 variable temperature unit. A Digitek digital thermocouple was used to measure the temperature of the sample in the probe.

Results and Discussion

At room temperature the nmr spectrum of dioxene consists of two singlets with relative intensities of 2 to 1, appearing at 3.96 and 5.86 ppm, respectively, downfield from tetramethylsilane. The former arises from the four methylene protons, two pseudoaxial and two pseudoequatorial, whose chemical-shift difference is averaged by the rapid ring inversion. The latter is that of the two equivalent olefinic protons.

Lowering the sample temperature below -150° reduces the rate of half-chair interconversion to the extent necessary to give the AA'BB' spectrum shown in the lower left corner of Figure 2. The parameters defining this slow exchange spectrum were evaluated with the help of a version of the LAOCOON 3 program.¹² Refinement of the parameters was accomplished through an iterative least-squares fit of the computed spectrum to the observed spectrum. The final calculated spectrum, shown in the lower right of Figure 2, yielded the parameters in Table I. The relative signs and magni-

(11) R. D. Moss and J. Paige, *J. Chem. Eng. Data*, **12**, 452 (1967).

(12) A. A. Bothner-By and S. M. Castellano, "Computer Programs for Chemistry," Vol. 1, D. F. Detar, Ed., W. A. Benjamin, New York, N. Y., 1968.

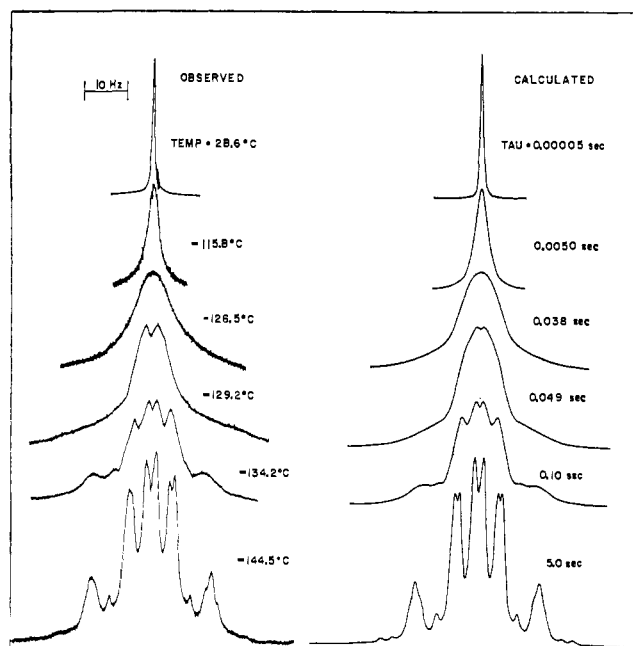

Figure 2. Experimental and calculated spectra of 1,4-dioxene at 100 MHz.

Table I. Proton Chemical Shifts (Hz) and Coupling Constants for 1,4-Dioxene^a

Chemical shifts ^b		Coupling constants	
Axial	388.6	Geminal	-11.88
Equatorial	404.4	Vicinal	
		$J_{a,a}$	9.98
		$J_{e,e}$	1.08
		$J_{a,e}$	2.02

^a In a 10% solution in vinyl chloride at -144.5° . ^b Measured downfield from TMS at 100 MHz.

tudes of the spin-spin coupling constants are consistent with those obtained in AA'BB' analyses on saturated six-membered ring molecules.^{13,14} However, the chemical-shift difference between axial and equatorial protons is a factor of 2 or 3 smaller than in cyclohexane and in the parent hydrocarbon, cyclohexene.⁷

The temperature dependence of the spectrum is shown in Figure 2. As the temperature is lowered, the signal corresponding to the methylene protons first broadens and then splits at about -129° . When the temperature reaches -145° , the final AA'BB' pattern is attained. In order to match the temperature dependence of the spectrum, a series of theoretical spectra was generated as a function of τ , the average time spent in either of the half-chair conformations. The rate constant for interconversion of the two half-chair conformers is equal to $1/\tau$. The calculations were made with a modification¹⁵ of the Whitesides-Lisle EXCNMR computer program.¹⁶ Input to the program includes the parameters of the slow-exchange spec-

(13) E. W. Garbisch, Jr., and M. S. Griffith, *J. Amer. Chem. Soc.*, **90**, 6543 (1968).

(14) H. S. Gutowsky and C. Juan, *Discuss. Faraday Soc.*, **34**, 52 (1962).

(15) J. K. Krieger, Ph.D. Thesis, Massachusetts Institute of Technology, 1971.

(16) G. M. Whitesides and J. S. Fleming, *J. Amer. Chem. Soc.*, **89**, 2855 (1967); J. S. Lisle, S.B. Thesis, Massachusetts Institute of Technology, 1968.

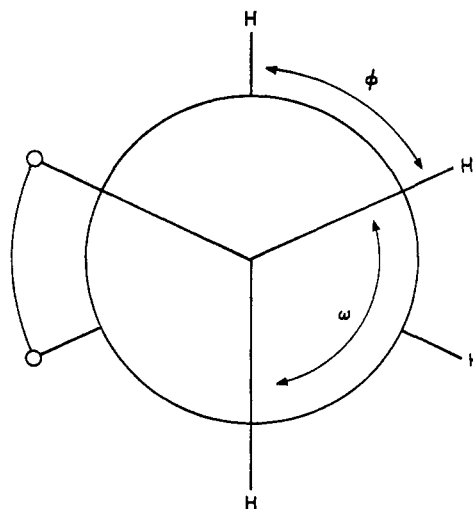

Figure 3. Definition of the dihedral angles in 1,4-dioxene.

trum, a value for τ , and an estimated value for the line width in the absence of exchange. The latter value was taken from the line width of the olefinic proton signal, which is not affected by the exchange process. The calculated spectra are compared with the observed spectra in Figure 2.

From the variation of τ with temperature, an Arrhenius plot, fitted by a least-squares computer program, yielded a value for the activation energy E_a of 7.62 ± 0.15 kcal/mol. Thermodynamic variables were calculated by the Eyring equation from the values of τ at various temperatures. At -125° the calculation yielded a free energy of activation (ΔG^\ddagger) for ring inversion of 7.32 ± 0.21 kcal/mol, an enthalpy of activation (ΔH^\ddagger) of 7.32 ± 0.15 kcal/mol, and an entropy of activation (ΔS^\ddagger) of -0.01 ± 1.04 gibbs.

The above activation energy for inversion agrees within experimental error with the barrier height determined from the far-infrared potential surface (Figure 1). This height above the potential minimum is 8.26 ± 0.8 kcal/mol,¹⁰ but for purposes of comparison with the activation energy, it needs to be reduced by the zero-point energy of the molecule in the two degrees of vibrational freedom in which the inversion occurs. From the eigenvalues of the potential surface¹⁰ the zero-point energy can be closely estimated as 0.68 kcal/mol, so that the barrier height above the zero-point plane is 7.58 ± 0.8 kcal/mol. In view of the fact that strictly speaking the activation energy and the barrier height are not necessarily the same quantity, and moreover that the far-infrared value was measured for the gas phase and the nmr value in vinyl chloride solution, the close correspondence of the two numbers is somewhat fortuitous.

The dihedral angle between protons on adjacent carbon atoms can be calculated from vicinal coupling constants according to the relation^{17,18}

$$J_{ij} = A(\cos^2 \phi + n \cos \phi) \quad (1)$$

For the angles ϕ and ω , defined in Figure 3, and the calculated coupling constants for dioxene, there results a set of three equations in four unknowns.¹³

(17) M. Karplus, *J. Amer. Chem. Soc.*, **85**, 2870 (1963).

(18) M. Barfield and D. M. Grant, *Advan. Magn. Resonance*, **1**, 149 (1965).

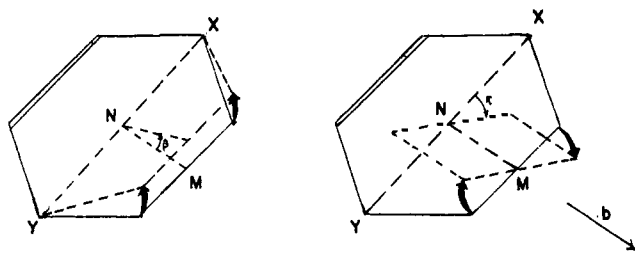

Figure 4. Definition of the ring-bending coordinate β and ring-twisting coordinate τ .¹⁰

$$\begin{aligned}
 J_{a,a} &= A[\cos^2(\omega + \phi) + n \cos(\omega + \phi)] \\
 J_{e,e} &= A[\cos^2(\omega - \phi) + n \cos(\omega - \phi)] \quad (2) \\
 J_{a,e} &= A[\cos^2 \phi + n \cos \phi]
 \end{aligned}$$

Assuming a tetrahedral H-C-H angle, $\omega = 120^\circ$, the equations yield $A = 8.73$, $n = -0.15$, and $\phi = 55.8^\circ$.

The potential surface shown in Figure 1 was calculated as a function of the bending angle β and the twisting angle τ . These angles are defined in Figure 4. The equilibrium angle of twist for the half-chair form was calculated to be 48.54° from far-infrared data. With the help of geometric relationships this angle can also be computed from the dihedral angle obtained from the proton coupling constants. If tetrahedral angles around the saturated carbon atoms and bond distances of 1.43 and 1.54 Å for the C-O and C-C bonds, respectively, are assumed, the equilibrium angle of twist τ is found to be 39.3° .

The discrepancy of 9° between this value and that obtained from the potential function is not surprising in view of the approximate nature of eq 2, the assumptions about the geometrical parameters needed in the calculation, and the method of obtaining the angle of twist from the potential surface itself. The last is the result of "substantial extrapolation of the potential surface as determined from eigenvalues near the potential minimum"¹⁰ and may be in error by several degrees.

When the present paper was submitted for publication, a referee called to our attention that Bushweller and O'Neil¹⁹ have examined the temperature dependence of the nmr spectrum of $\Delta^{2,3}$ -dihydropyran and have estimated a barrier (identified with ΔG^\ddagger) to inversion for the ring of 6.6 ± 0.3 kcal/mol at -140° . The potential surface for this molecule has also been computed from far-infrared data in ref 10. Thus, we have a second example of a barrier height determined by both spectroscopic methods. The far-infrared spectrum and potential surface for $\Delta^{2,3}$ -dihydropyran are qualitatively quite similar to those for dioxene. The height of the saddle point above the potential minimum¹⁰ is 6.94 ± 0.7 kcal/mol. Correction for the zero-point energy yields a barrier height above the zero-point level of 6.31 ± 0.7 kcal/mol.

The results of these two investigations^{10,19} cannot be directly compared since only ΔG^\ddagger was determined rather than ΔE_a in the nmr study. However, if ΔG^\ddagger for $\Delta^{2,3}$ -dihydropyran is compared with the corresponding quantity of 7.32 kcal/mol for dioxene (both at -140°), the difference of 0.7 kcal/mol is in fair agreement with the difference in far-infrared barriers of 1.27 kcal/mol. The disagreement is probably the result of the approximate nature of the treatment of the nmr data for $\Delta^{2,3}$ -dihydropyran.

To examine further the question of the measurement of the inversion barrier by far-infrared and nmr methods, we are studying both kinds of spectra for $\Delta^{3,4}$ -dihydropyran in collaboration with Professor T. B. Malloy, Jr.

Acknowledgments. We thank Professor G. M. Whitesides and Dr. J. K. Krieger for the use of their computer programs and Dr. Krieger for helpful discussion on their use. We also thank Mr. M. McCreary for aid in obtaining the 100 MHz nmr spectra. The sample of 1,4-dioxene was synthesized by Dr. T. C. Rounds. This work was supported by the National Science Foundation (GP-13473) and the National Institutes of Health (GM-15310).

(19) C. H. Bushweller and J. W. O'Neil, *Tetrahedron Lett.*, 4713 (1969).

Internal Rotation and Methyl Proton Magnetic Relaxation for Macromolecules

Lawrence G. Werbelow* and Alan G. Marshall

Contribution from the Department of Chemistry, University of British Columbia, Vancouver 8, Canada. Received March 12, 1973

Abstract: Two simplified treatments for proton magnetic relaxation for a methyl group on a macromolecule are analyzed. An error in a previous Solomon-type treatment is explained and rectified. Various ways of using T_1 and T_2 values, either separately or in conjunction or at different magnetic fields, are considered. It is concluded that T_1 provides a good approximate estimate of the internal rotation rate, which may then be combined with the approximate rotational correlation time of the macromolecule as a whole (based on its molecular weight) to obtain an estimate of the internal rotation angle from T_2 .

Many attempts to study the flexibility at specific sites on macromolecules from measurement of nuclear relaxation times have been based on use of -CO-

CH₃ or -COCF₃ groups, on account of their superior signal-to-noise (compared with -CH or -CH₂ groups) and lack of scalar coupling (resulting in a single reso-